



basic education

Department:
Basic Education
REPUBLIC OF SOUTH AFRICA

**NATIONAL
SENIOR CERTIFICATE**

GRADE 12

AGRICULTURAL SCIENCES P2
NOVEMBER 2011
MEMORANDUM

MARKS: 150

**DEPARTMENT OF BASIC
EDUCATION**

2011 -11- 10
PRIVATE BAG X 110
PRETORIA 0001
PUBLIC EXAMINATIONS

DHA Smuts
Internal Moderator
13-11-2011

This memorandum consists of 9 pages.

Approved
Dr FE Khumalo
EXT moderator
UMALUZI
13/11/2011

Approved
SM Gwensa
Ext. Moderator
Umaluzi
13-11-2011

SECTION A**QUESTION 1.1**

1.1.1	A	B	C	X✓✓
1.1.2	A	B	C	X✓✓
1.1.3	A	X✓✓	C	D
1.1.4	X✓✓	B	C	D
1.1.5	X✓✓	B	C	D
1.1.6	A	X✓✓	C	D
1.1.7	A	X✓✓	C	D
1.1.8	A	B	C	X✓✓
1.1.9	X✓✓	X✓✓	C	D
1.1.10	A	B	C	X✓✓

(10 x 2) (20)

QUESTION 1.2

1.2.1	D✓✓
1.2.2	A✓✓
1.2.3	J✓✓
1.2.4	C✓✓
1.2.5	E✓✓

(5 x 2) (10)

QUESTION 1.3

- 1.3.1 Budget/business/enterprise plan ✓✓
 1.3.2 Cooperative ✓✓
 1.3.3 Multi segmented ✓✓
 1.3.4 Electroporation/genetic manipulation/engineering/biotechnology ✓✓
 1.3.5 Genetics ✓✓

(5 x 2) (10)

QUESTION 1.4

- 1.4.1 Research ✓
 1.4.2 Mass ✓
 1.4.3 Crossbreeding/out breeding ✓
 1.4.4 Private ✓
 1.4.5 Manager/entrepreneur/owner ✓

(5 x 1) (5)

TOTAL SECTION A: 45

Handwritten signature and initials, possibly 'F.K.' and 'S.M.', with a circular scribble above the signature.

SECTION B**QUESTION 2: AGRICULTURAL MANAGEMENT****2.1 Financial record keeping****2.1.1 Importance of keeping financial records**

- To manage the capital of a farm/determine profit or loss /idea of income and expenses✓
- To analyse past and current performance/analyse success of business ✓
- Plan for the future of the farm /budgeting/replanning✓
- Proof of payment/Tax purposes✓

(Any 2) (2)

2.1.2 Total transport cost

$$R80,00 + R40,00 + R80,00 = R200,00 \checkmark\checkmark\checkmark$$

OR

$$R80,00 + R40,00 + R80,00 \checkmark = R200,00 \checkmark\checkmark$$

(3)

$$\begin{aligned} 2.1.3 \quad \text{Profit} &= \text{income} - \text{expenses} \checkmark \\ &= R\ 2\ 058 - R\ 1\ 093 \checkmark \\ &= R\ 965 \checkmark\checkmark \end{aligned}$$

OR

$$\begin{aligned} \text{Profit} &= \text{income} - \text{expenses} \checkmark \\ &= R\ 2\ 093 - R\ 1\ 093 \checkmark \\ &= R\ 1\ 000 \checkmark\checkmark \end{aligned}$$

(4)

- 2.1.4 • Farm workers receive eggs for free/4 dozen eggs were given to workers✓✓

(2)

2.1.5 Creation of capital

- Production/layers✓ – created when more eggs are produced and then offered to generate capital✓
- Capital needed to start a business is obtained by means of credit/loan✓supplied by financial institutions/ABSA/bank✓
- Savings✓ – farming profits are allowed to accumulate in the bank✓

(Any 2 x 2) (4)

2.2 Cellphones beat stock thieves**2.2.1 TWO reasons for investing in high-tech anti-stock theft security systems**

- For the fight against stock theft/to notify when animals are in danger ✓
- Indication of the time when mating takes place/assist in management/saves time and labour ✓
- Indication of the ram and ewe that were involved in mating✓
- Tracking/monitoring the movement of animals ✓
- To determine grazing patterns of animals✓

(Any 2) (2)

2.2.2 **TWO important entrepreneurial skills of the manufacturers**

- Creativity✓ - involve new ideas that are put to test/first of its kind✓
- Innovation✓ - the systems are of a high-tech nature/it is a futuristic apparatus that can accommodate many uses ✓
- Marketing/communication✓ - convince the clients to use the apparatus✓
- Technical ✓ - knowledge on installing of the apparatus✓
- Research/problem solving ✓ - determine the opportunity in the market✓
- Risk orientation✓ - high initial investment for the manufacturer

(Any 2) (4)

2.3 **Entrepreneurial success factors[Only used once]**

- 2.3.1 Motivation/appreciation ✓ (1)
- 2.3.2 Punctuality ✓ (1)
- 2.3.3 Appreciation/motivation ✓ (1)
- 2.3.4 Leadership ✓ (1)

2.4 **The demand and supply graph**

- 2.4.1
- Reversed relationship/As the quantities supplied increases ✓ the demand for the product will decrease ✓
- OR**
- Reversed relationship As the quantities demanded increases ✓ the supply of a agricultural product would decrease ✓ (2)
- 2.4.2
- A point where the amount demanded by the market and the amount supplied ✓ are equal ✓
- OR**
- Supply =✓ demand✓ (2)
- 2.4.3
- Equilibrium price high/R30 at supply (before) and low/R20 at supply (after)/the supply described as before had an equilibrium price that was higher ✓
 - Compared to the situation after ✓ (2)
- 2.4.4
- Quantities before: 200 ✓
 - Quantities after: 300 ✓ (2)
- 2.4.5
- Graph B ✓
 - The demand was higher after the promotion/demand before was 200 and then increased to 300 ✓ (2)

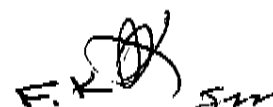
[35]

QUESTION 3: PRODUCTION FACTORS AND MANAGEMENT**3.1 Recordkeeping: physical and financial records**

3.1.1

(a)	(b)
<ul style="list-style-type: none"> • Borehole with a wind mill ✓ • Farm shed ✓ (2) 	<ul style="list-style-type: none"> • Tractor ✓ • Bakkie(Farm van) ✓ (2)

(4)

3.1.2

THREE sources of capital

- Commercial Bank ✓
- Land Bank ✓
- Development Finance Corporation Ltd. ✓
- Insurance companies ✓
- Agricultural cooperatives ✓
- Agricultural business partners ✓

(Any 3) (3)

3.1.3

- Net worth is the difference between ✓ the value of your assets ✓ and the value of your liabilities ✓

(3)

3.2

THREE functions of land as a production factor:

- Provides space ✓
- Provides raw materials ✓
- Provides food for humans and animals ✓
- It is a source of minerals used as fertilisers ✓

(Any 3) (3)

3.3

Approaches to management

3.3.1

Farmer A:

- Sound financial management ✓
- Neatness/orderly
- Humanitarian relations/caring towards labour ✓

(Any 1)

Farmer B:

- Money saving approach/stingy farmer ✓
- Savings(worthiness record)/cash operation
- Not caring towards labourers/bad human relations ✓

(Any 1) (2)

3.3.2

Farmer A ✓

and

Built new homes for workforce/water and electricity to workers/neatness stimulates motivation ✓

(2)

E.K.  S.M.

3.4 Coordination of production factors

- 3.4.1 (a) A ✓ (1)
 (b) C ✓ (1)
 (c) F/D ✓ (1)
 (d) B/E ✓ (1)
 (e) E ✓ (1)
- 3.4.2 • Supervision/Control/Coordination/organising ✓
 • Entrepreneur is supervising workers according to the plan ✓ (2)
- 3.4.3 • Planning skills ✓
 • Financial skills ✓
 • Management skills ✓
 • Human relations skills ✓
 • Risk orientation skills ✓
 • Communication skills ✓
 • Leadership skills ✓
 • Marketing skills ✓
 • Organisational skills ✓
 • Motivational skills ✓
 • Problem solving ✓ (Any 2) (2)
- 3.4.4 Owner/Farmer/Manager/Entrepreneur/A ✓ (1)

3.5 Labour management

- 3.5.1 B ✓ (1)
 3.5.2 A ✓ (1)
 3.5.3 D ✓ (1)
 3.5.4 E ✓ (1)
 3.5.5 B/D ✓ (1)

3.6 Labour legislation

- 3.6.1 (a) **The labour Relations Act (1995)**
 • It governs labour relations at workplace/unfair labour practices/regulates trade union activities ✓
 • It governs the involvement of workers in decision making ✓
 • It governs procedures for labour disputes/right to strike ✓
 (Any 1) (1)

 F.K. S.M.

(b) Occupational Health and Safety Act (1993)

- It deals with the safety of workers in the workplace/mutual responsibility on safety ✓
- It makes the farmer responsible to ensure that the working environment is safe ✓
- It holds the farmer responsible to provide protective clothing to workers ✓
- It holds the farmer responsible to train workers on operating machinery or equipment ✓

(Any1) (1)

3.6.2 The Compensation for Occupational Injuries and Diseases Act ✓

(1)

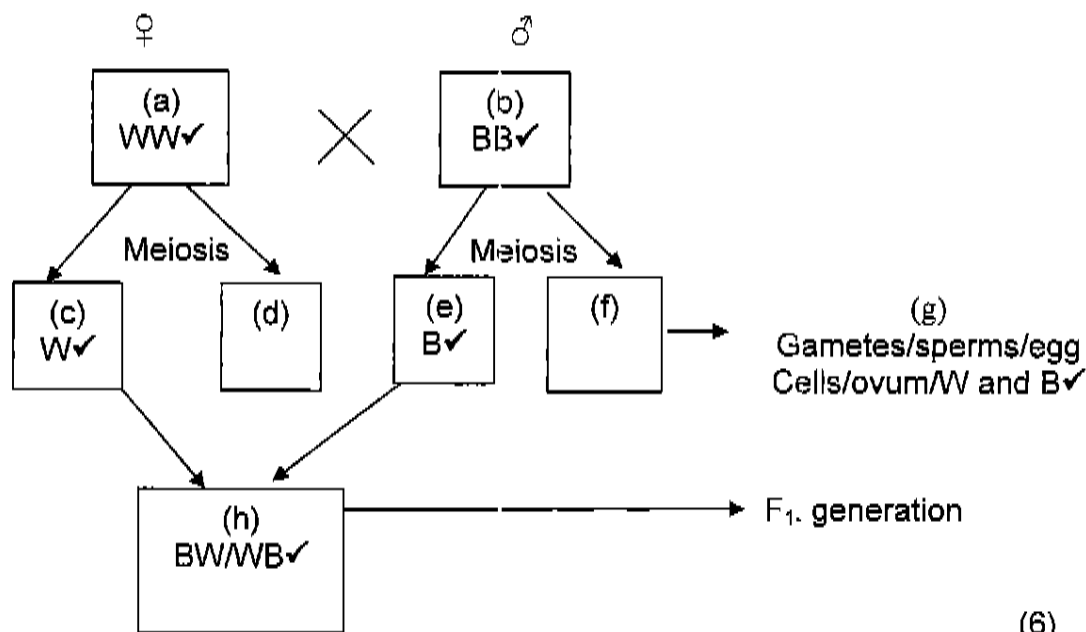
[35]**QUESTION 4: BASIC AGRICULTURAL GENETICS****4.1 Illustration of incomplete dominance****4.1.1 Completion of the missing answers in the blocks**

(6)

4.1.2 Incomplete dominance ✓

(1)

4.1.3 Motivation on the type of dominance

- Parents of P₁ have only homozygous (pure-bred) dominant genes/intermediate phenotype is shown in the offspring/none of the colours of parents are visible in the offspring ✓
- There are no recessive genes in all the generations ✓
- The phenotypic ratio of the F₂ is 1:2:1 ✓

(Any 2) (2)

4.1.4 Testes/Ovary/Primary sex organs/Primary reproductive organs ✓

(1)

F. K. SM

4.2 Crossing of farm animals

- 4.2.1 Black ✓ and white ✓ (2)
- 4.2.2 Male ✓ (1)
- 4.2.3 $2/4 \times 100 \checkmark = 50\% \checkmark$
OR
50% ✓✓ (2)

4.3 Indigenous cattle breeds of South Africa

- 4.3.1 Indigenous cattle breeds of South Africa/Nguni cattle are reintroduced ✓ (1)
- 4.3.2 **Adaptation qualities of Nguni cattle**
- Resistant to a number of diseases ✓
 - Resistant to internal and external parasites ✓
 - Adapted to high excessive heat conditions ✓
 - High fertility ✓
 - Short calving interval ✓
 - High adaptation to poor quality grazing ✓
 - Long productive lifespan ✓
- (Any 3) (3)

4.4 Schematic representation of line breeding

- 4.4.1
- 13 ✓
 - 5 ✓
 - 7 ✓
- (3)
- 4.4.2 **Benefits of upgrading to livestock farmers**
- A new breed is gradually imported into the herd/fewer adaptation problems ✓
 - Economical way to raise the stock to a pedigree level ✓
 - Initial rapid results(50% improvement in first generation) ✓
 - Deformities and unwanted characteristics occur less frequent ✓
 - Expert knowledge not needed ✓
 - Creates a more uniform herd ✓
- (Any 3) (3)

4.5 FOUR selection methods used by livestock breeders

- Mass/individual selection ✓
 - Pedigree selection/blup ✓
 - Family selection ✓
 - Progeny selection/performance of progeny ✓
 - Natural selection ✓
 - Breeding values ✓
- (Any 4) (4)

F. K.  SM

4.6 Genetically modified sorghum

- 4.6.1
- Enriched with vitamins ✓
 - Balanced in terms of nutrition/prevent malnutrition ✓
 - To alleviate the problem of poverty/hunger in Africa ✓
 - Improve cultivars ✓
 - Improved seed appropriate for planting ✓
- (Any 2) (2)
- 4.6.2
- GM sorghum will be vitamin enriched (packed) ✓
 - to help fight malnutrition ✓
- (2)
- 4.6.3
- TWO dangers of GM food**
- GM food risk destabilising the environment/Contamination of local seed stocks ✓
 - GM food risk destabilising food production ✓
 - Socio-economic concerns ✓
 - Food safety/health risk ✓
- (Any 2) (2)

[35]

TOTAL SECTION B: 105
GRAND TOTAL: 150